

PRODUCT DATA SHEET

DAB-200M • 701398



PRODUCT DETAILS

The pump is a self-priming surface mounted jet pump and has a suction capability of up to 8m.

APPLICATIONS

- Domestic installations where a suction lift is required
- Pressure boosting, irrigation and wash down
- Designed for pumping from tanks, rivers and dams.

FEATURES

- Self priming centrifugal pump with excellent suction capability
- 240V single phase TEFC motor with in-built auto reset thermal overload to prevent pump from damage

BRAND



TECHNICAL DATA

MATERIALS IN CONTACT WITH DRINKING WATER

PUMP

PUMP BODY	GJL 200 Cast Iron
IMPELLER	Glass reinforced Noryl
JET, VENTURI, DIFFUSER	Glass reinforced Noryl
MECHANICAL SEAL	Carbon Ceramic Nitrile
O RINGS	Nitrile

SPECIFICATIONS

RATED POWER (KW)	1.47 (2hp)
MAX. FLOW [LPM]	185
MAX. HEAD [M]	41
PORTS	40mm x 32mm (1-1/2"x1-1/4")BSP
VOLTS (V)	240
CARTON DIMENSIONS	612mm L x 248mm W x 279mm H
WEIGHT (KG)	27

CURVE

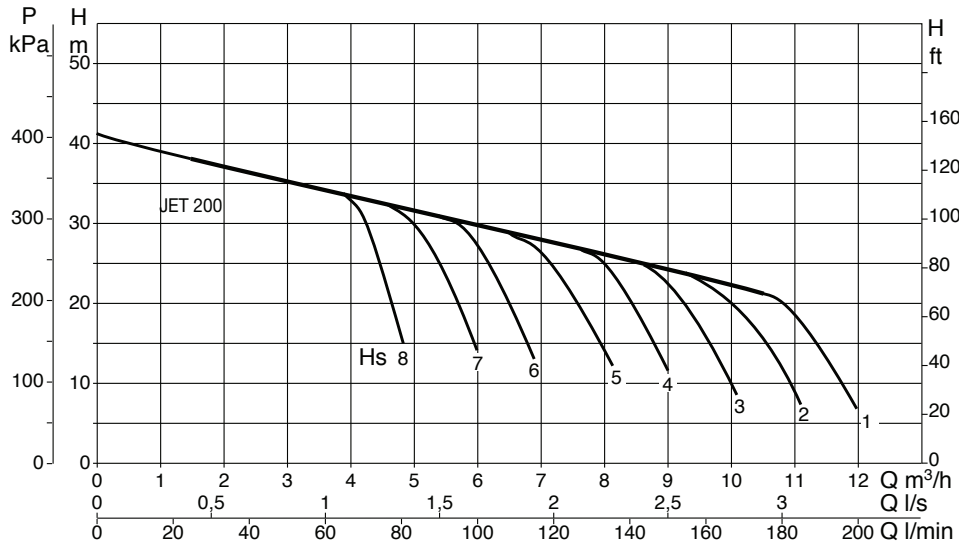

DIMENSIONS

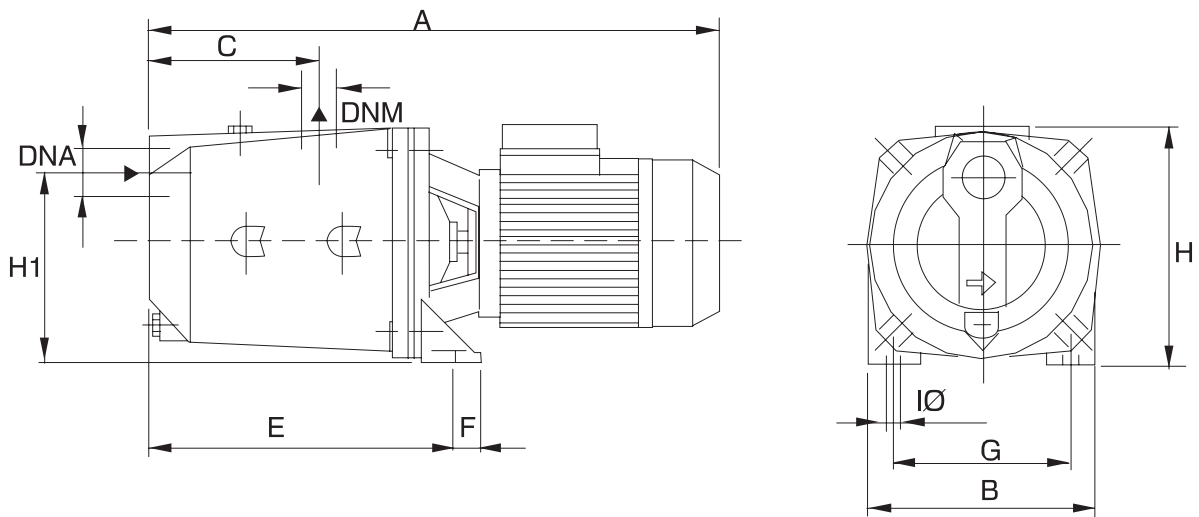

MODEL	A	B	C	E	F	G	I Ø	H	H1	DNA GAS	DNM GAS
JET 200	521	214	151	282	20	160	11	227	175	1½"	1¼"

WARRANTY / CERTIFICATIONS

